

Checkflo

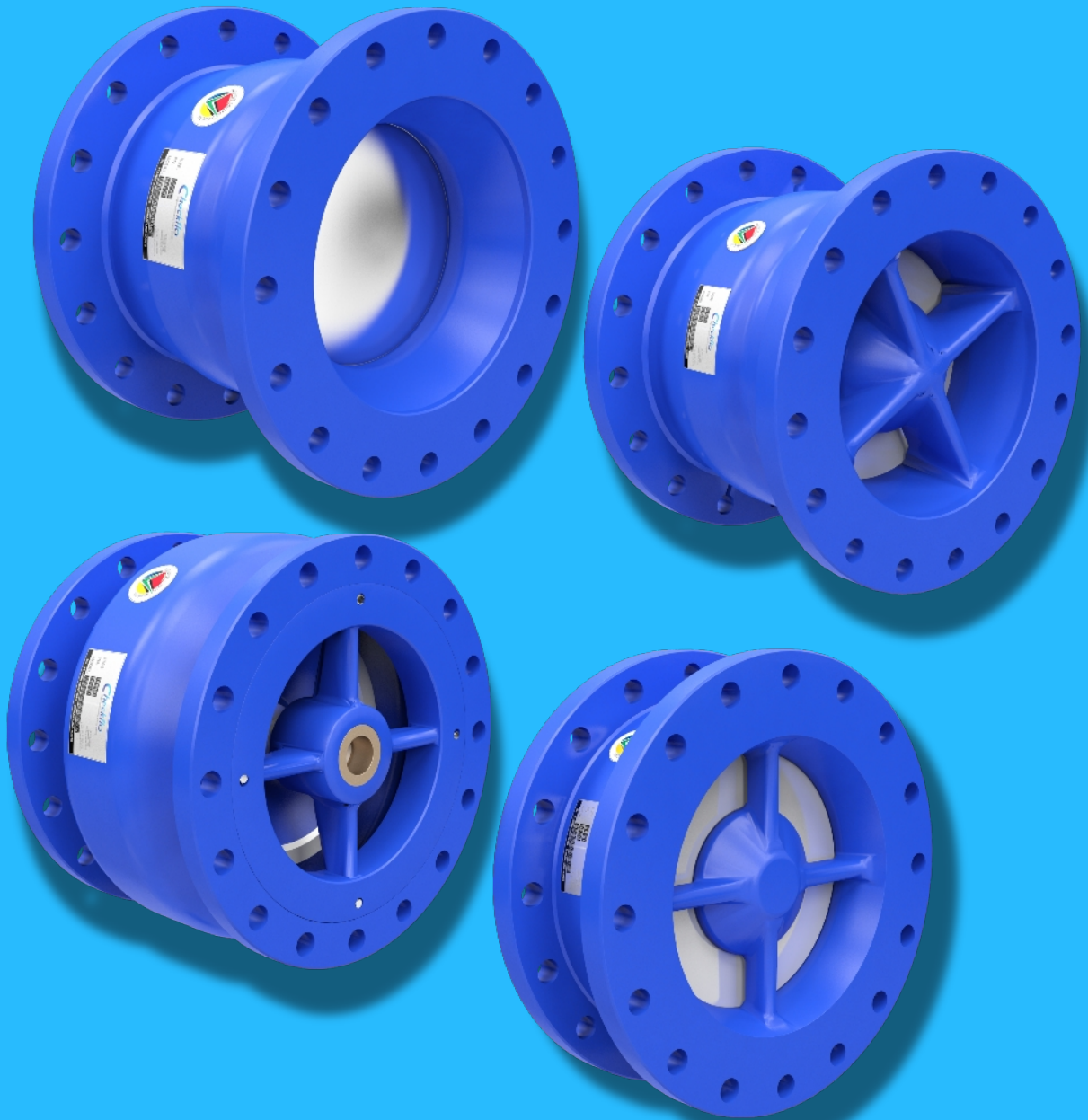

CheckFlo Nozzle and Silent Check Valves

High Performance Check Valves for Optimum Surge Protection



Nozzle Check and Silent Check Valves

The Problem

Check Valves (Non Return Valves) are placed subsequent to pumps, to prevent backflow upon pump trip.

Ideally a Check Valve should open with the onset of upstream pressure and allow flow through the valve with minimal resistance. The valve should close at the instant of zero flow velocity and remain positively closed and should resist back pressure without leakage.

Due to compact construction requirements in a pump house, a Check Valve should preferably also have a short laying length.

Check Valves come in a confusion of designs and each design functions differently. Some designs provide a short lay length but create water hammer upon closure, others have an excellent head loss characteristic but have a very long lay length whilst other designs prevent water hammer but have excessively high head loss characteristics.

The Challenge

Manufacturers have over the years been challenged to develop Check Valves that balance the need for non-slam features with good head loss characteristics and short lay lengths to not only reduce the overall pump house design but also reduce the initial capital cost of the valve. A further requirement is the reduction of operating and maintenance costs.

CheckFlo High Performance Check Valves - The Solution

CheckFlo provides, a range of Silent Check and Nozzle Check Valves that prevent Water Hammer and reverse flow and insure long and trouble free operation.

Each check valve in our range balances the capital cost with ease of installation and performance to provide an optimum solution to the end user.

CheckFlo valves were designed utilising the latest in Finite Element Analysis (FEA) and Computational Fluid Dynamics (CFD) software. Each validated design was heavily prototyped and refined followed by independent flow and hydrostatic testing. This has resulted in a light weight moving assembly with excellent flow and dynamic characteristics for each design type.

One of the most important design criterion in all CheckFlo valve designs is the behaviour of the disc under various flow conditions. The result is that CheckFlo Check Valves are the best combination of superior flow efficiency and excellent dynamic response in any check valve product range currently available.

CheckFlo is manufactured in our ISO 9001 and OHSAS 18001 certified manufacturing facility.



INDEX

CheckFlo Check Valves Design Options	1
Materials of Construction Series DGB Nozzle Check Design	2-3
Materials of Construction BCB Nozzle Check Design	4-5
Materials of Construction Series AGB Silent Check Design	6
Dimensions & Weights DGB Nozzle Check Design	7-8
Dimensions & Weights BCB Nozzle Check Design	9-10
Dimensions & Weights AGB Silent Check Design	11
Performance Characteristics of CheckFlo Check Valves	12-14
Check Valve Selection Criteria	15-20
Check Valve Model Numbers	20

Design Options

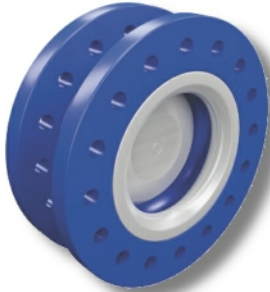

CheckFlo Series DGB Nozzle Check Valves

Size Range: DN 50 - DN 1200 - Larger valves based on request
Pressure Range: PN 10 - PN 63

Features

- Non slam closure • Low pressure loss • Maintenance free
- Metal to Metal or Soft Seal options • Highly customisable
- Choice of Face to Face length

The venturi design and streamlined flow path allows for high pressure recovery and minimising pressure drop across the valve. This efficient design combined with the highly responsive non slam operation makes it ideal for critical pump applications.

Type DGB-SF - This is a short face to face Central Shaft design available in both wafer and flanged options, this design is perfect for conditions where surge protection is imperative and where space and weight is at a premium.

Type DGB-LF – This is a long face to face Central Shaft design. Its optimum designed aerodynamic flow path results in very low pressure losses. It is also available in customised face to face lengths.

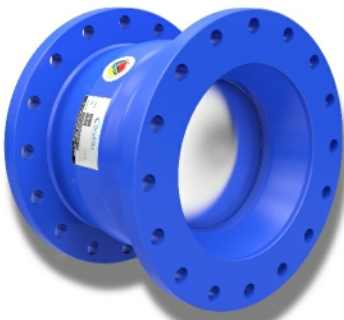

CheckFlo BCB Nozzle Check Valves

Size Range: DN 50 - DN 1200 - Larger Size available on request
Pressure Range: PN 10 - PN 63

- Non-slam closure • Low pressure loss • Maintenance free
- Metal to Metal sealing • Low friction disc guiding

The Annular Ring design consists of ring disc mounted on a multiple spring and radial guide assembly thereby minimising the frictional forces and ensures quick closure.

The annular flow paths, the valve profile and the diffuser combine to ensure that the valve provides excellent pressure recovery properties and minimal headloss characteristics.

Type BCB-SF - The Annular disc design is a short face to face design that provides the customer a reduced weight and a lower cost solution in applications where marginally higher pressure drops can be accepted.

Type BCB-LF – This is a longer face to face Annular Ring disc design that provides optimum pressure recovery performance hence minimum pressure loss.

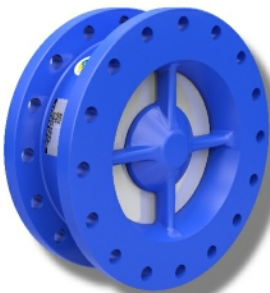

CheckFlo Series AGB Silent Check Valves

Size Range: DN 80 - DN 1000
Pressure Range: PN 10 - PN 40

Features

- Non-slam closure • Metal to Metal or Soft sealing
- Maintenance free

The CheckFlo Silent Check valve provides an economical solution to surge and waterhammer in applications where higher pressure drops and a slightly slower response times are acceptable.



Series DGB-SF Nozzle Check Valves Materials of Construction

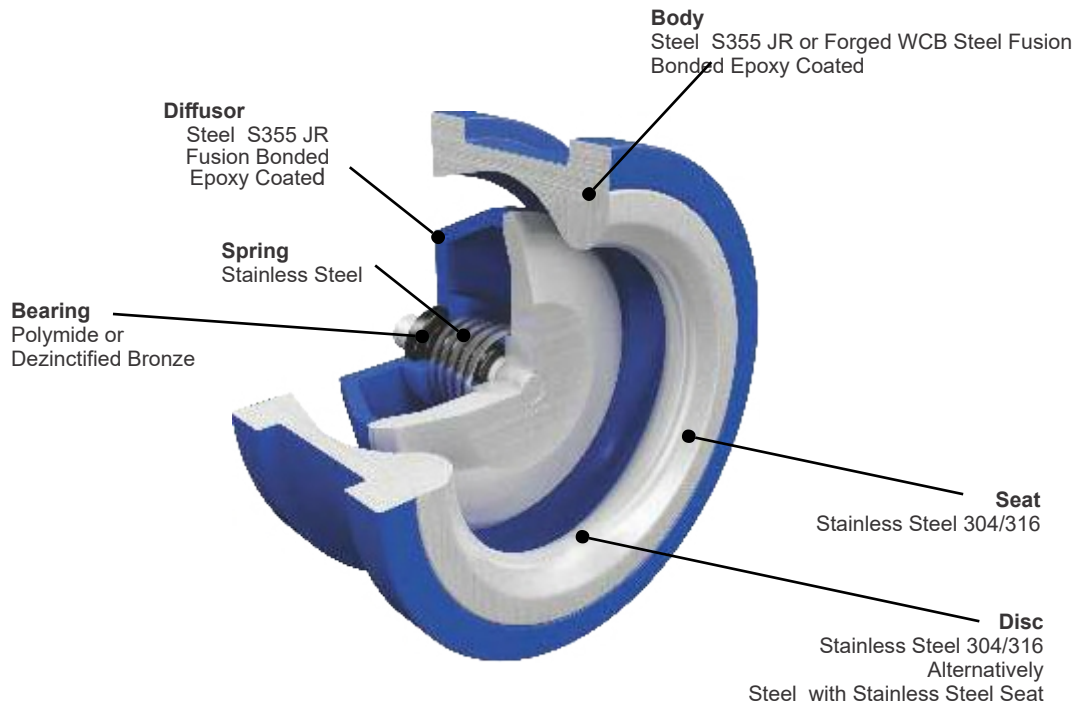

Series DGB-SF Nozzle Check Valves Features and Benefits

- **Compact design** - Our Nozzle Check design provide a short face-to-face for economical design of pump stations without compromising performance.
- **Maintenance free** – The valve has only one moving part resulting in minimal wear and long service life. In addition, the Venturi design streamlines flow resulting in very low pressure drops across the valve and in the elimination turbulence and vibrations.
- **Surge protection** – All CheckFlo designs have a short stroke and a quick dynamic response minimises damaging water hammer.
- **Energy saving** – The valve body, disc and diffuser are specifically designed for low pressure loss across the valve. Flow paths through the valve are specifically profiled to ensure full opening of the disc at low flows. In addition, the force of the spring is overcome by a low pressure zone behind the disc during flow conditions thereby further reducing head losses across the valve.
- **Tight shutoff** – This is accomplished by means of metal-to-metal conical seating for perfect self-alignment or alternatively a soft dynamic seat can be provided on request.
- **Highly customisable** – CheckFlo Series DGB is designed to suit almost any application and can be supplied in a wide variety of materials, seat designs, end connections, pressure ratings and face-to-face dimension to suit the client's application.
- **Technical support** – We provide assistance with surge analysis and protection strategies as well as spring selection for specific critical velocity and valve response requirements.

CheckFlo Series DGB Nozzle Check Valves are aligned with AirFlo Variable Orifice air valves to minimise surge and water hammer in pipeline systems.

Series DGB-LF Nozzle Check Valves Materials of Construction

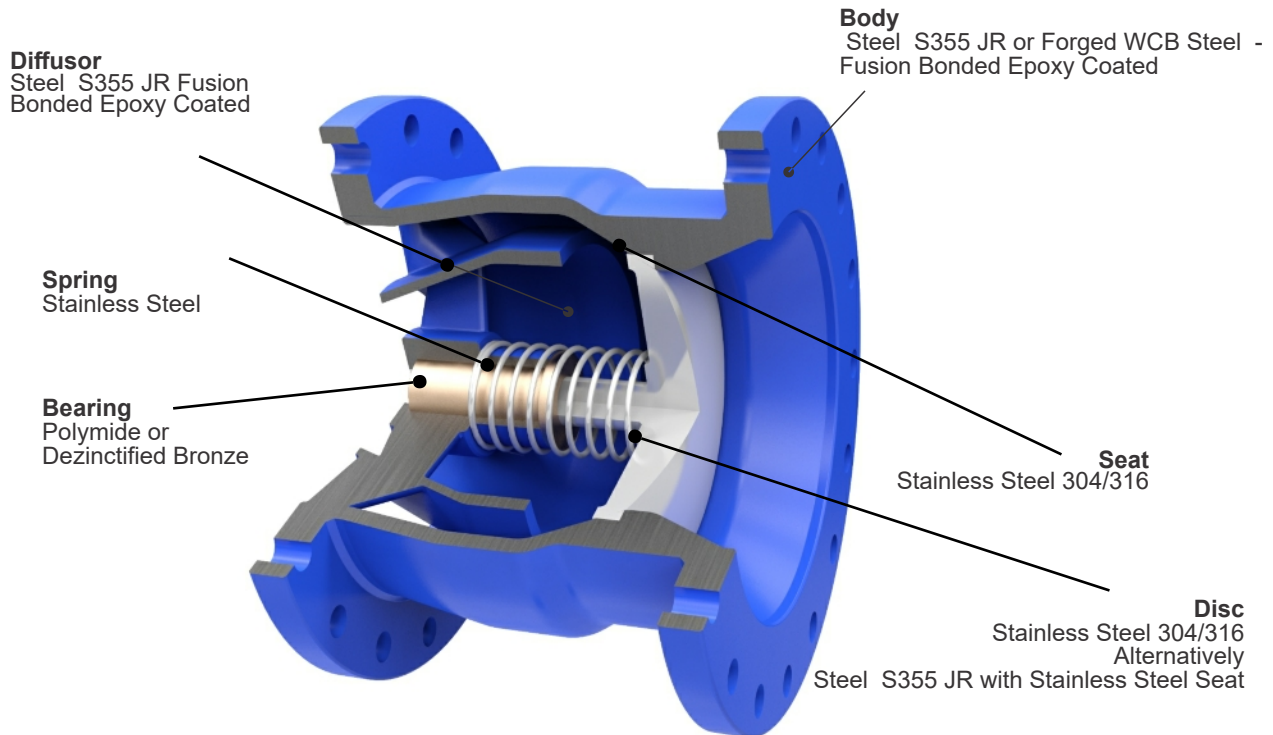

Series DGB-LF Nozzle Check Valves Features and Benefits

- **Very low headloss** - Our Nozzle Check design provide an economical design with longer face to face than our standard design thus providing extremely low headloss characteristics.
- **Maintenance free** – The valve has only one moving part resulting in minimal wear and long service life. In addition, the Venturi design streamlines flow resulting in very low pressure drops across the valve and in the elimination turbulence and vibrations.
- **Surge protection** – All CheckFlo designs have a short stroke and a quick dynamic response minimising damaging water hammer.
- **Energy saving** – The valve body, disc and diffuser are specifically designed for low pressure loss across the valve. Flow paths through the valve are specifically profiled to ensure full opening of the disc at low flows. In addition, the force of the spring is overcome by a low pressure zone behind the disc during flow conditions thereby further reducing head losses across the valve.
- **Tight shutoff** – This is accomplished by means of metal-to-metal conical seating for perfect self-alignment or alternatively a soft dynamic seat can be provided on request.
- **Highly customisable** – CheckFlo Series DGB is designed to suit almost any application and can be supplied in a wide variety of materials, seat designs, end connections, pressure ratings and face to face dimension to suit the client's application.
- **Technical support** – We provide assistance with surge analysis and protection strategies as well as spring selection for specific critical velocity and valve response requirements.

CheckFlo Series DGB Nozzle Check Valves are aligned with AirFlo Variable Orifice air valves to minimise surge and water hammer in pipeline systems.

Series BCB-SF Nozzle Check Valves Materials of Construction

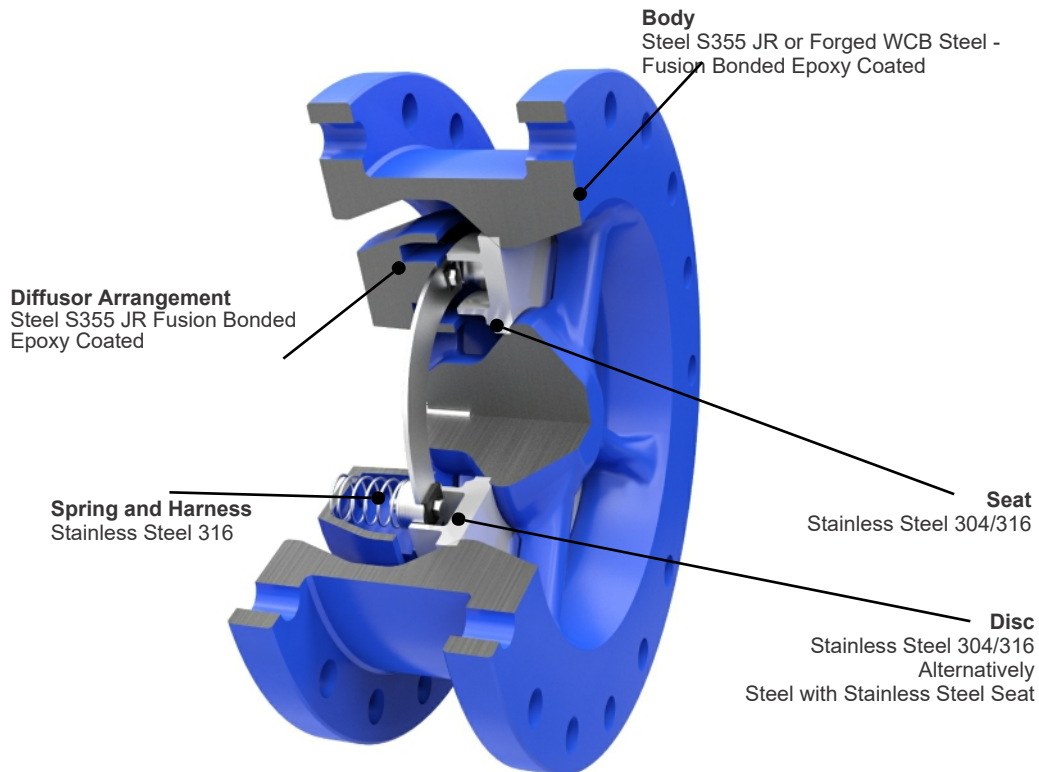

Series BCB-SF Nozzle Check Valves Features and Benefits

- **Compact design** - Our Nozzle Check design provide a short face-to-face for economical design of pump stations without compromising performance.
- **Maintenance free** – The valve has only one moving part resulting in minimal wear and long service life. In addition, the Venturi design streamlines flow resulting in very low pressure drops across the valve and in the elimination turbulence and vibrations.
- **Surge protection** – All CheckFlo designs have a short stroke and a quick dynamic response minimising damaging water hammer.
- **Energy saving** – The valve body, disc and diffuser are specifically designed for low pressure loss across the valve. Flow paths through the valve are specifically profiled to ensure full opening of the disc at low flows. In addition, the force of the spring is overcome by a low pressure zone behind the disc during flow conditions thereby further reducing head losses across the valve.
- **Tight shutoff** – This is accomplished by means of metal-to-metal seating for perfect self-alignment.
- **Technical support** – We provide assistance with surge analysis and protection strategies as well as spring selection for specific critical velocity and valve response requirements.

CheckFlo Series BCB Nozzle Check Valves are aligned with AirFlo Variable Orifice air valves to minimise surge and water hammer in pipeline systems.

Series BCB-LF Nozzle Check Valves Materials of Construction

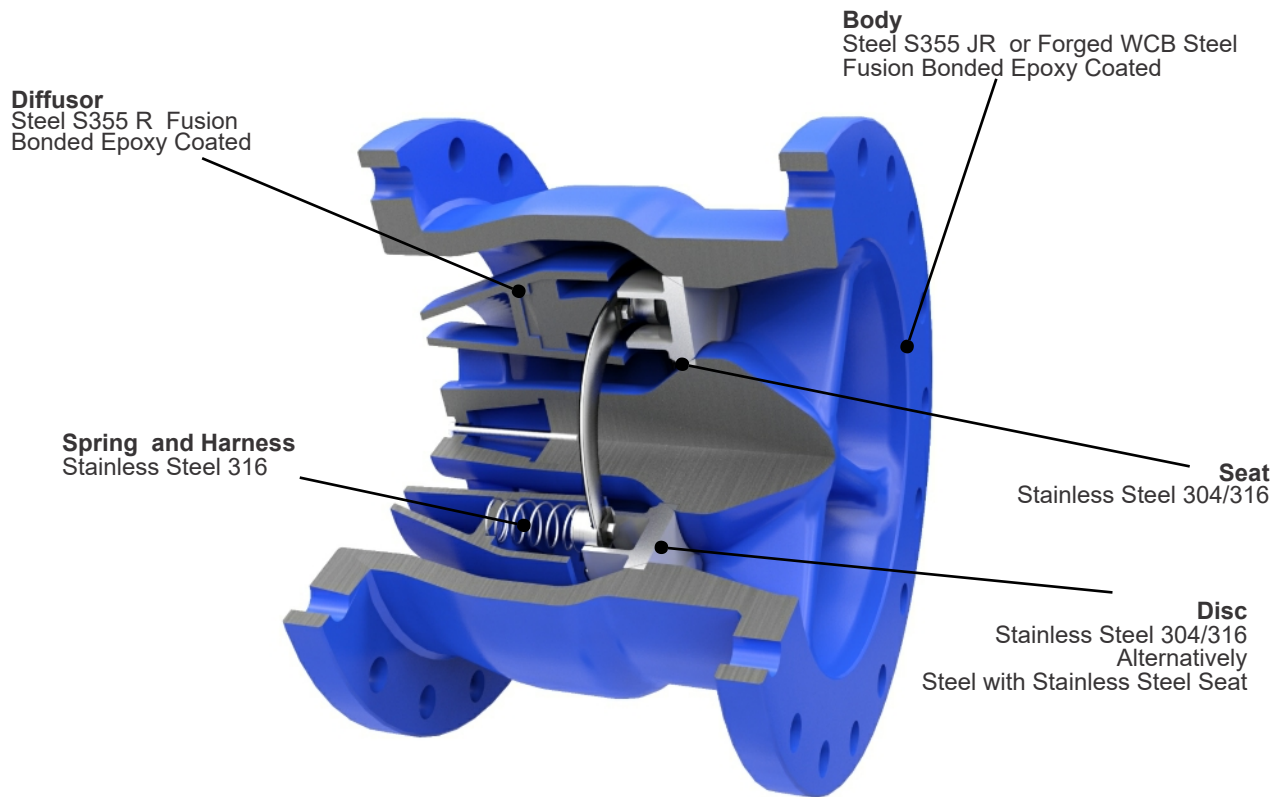

Series BCB-LF Nozzle Check Valves Features and Benefits

- **Very low headloss** - Our Nozzle Check design provide an economical design with longer face-to-face than our standard design thus providing extremely low headloss characteristics
- **Maintenance free** – The valve has only one moving part resulting in minimal wear and long service life. In addition, the Venturi design streamlines flow resulting in very low pressure drops across the valve and in the elimination turbulence and vibrations.
- **Surge protection** – All CheckFlo designs have a short stroke and a quick dynamic response minimising damaging water hammer.
- **Energy saving** – The valve body, disc and diffuser are specifically designed for low pressure loss across the valve. Flow paths through the valve are specifically profiled to ensure full opening of the disc at low flows. In addition, the force of the spring is overcome by a low pressure zone behind the disc during flow conditions thereby further reducing head losses across the valve.
- **Tight shutoff** – This is accomplished by means of metal-to-metal conical seating for perfect self-alignment or alternatively a soft dynamic seat can be provided on request.
- **Technical support** – We provide assistance with surge analysis and protection strategies as well as spring selection for specific critical velocity and valve response requirements.

CheckFlo Series BCB Nozzle Check Valves are aligned with AirFlo Variable Orifice air valves to minimise surge and water hammer in pipeline systems.

Series AGB Silent Check Valves Materials of Construction

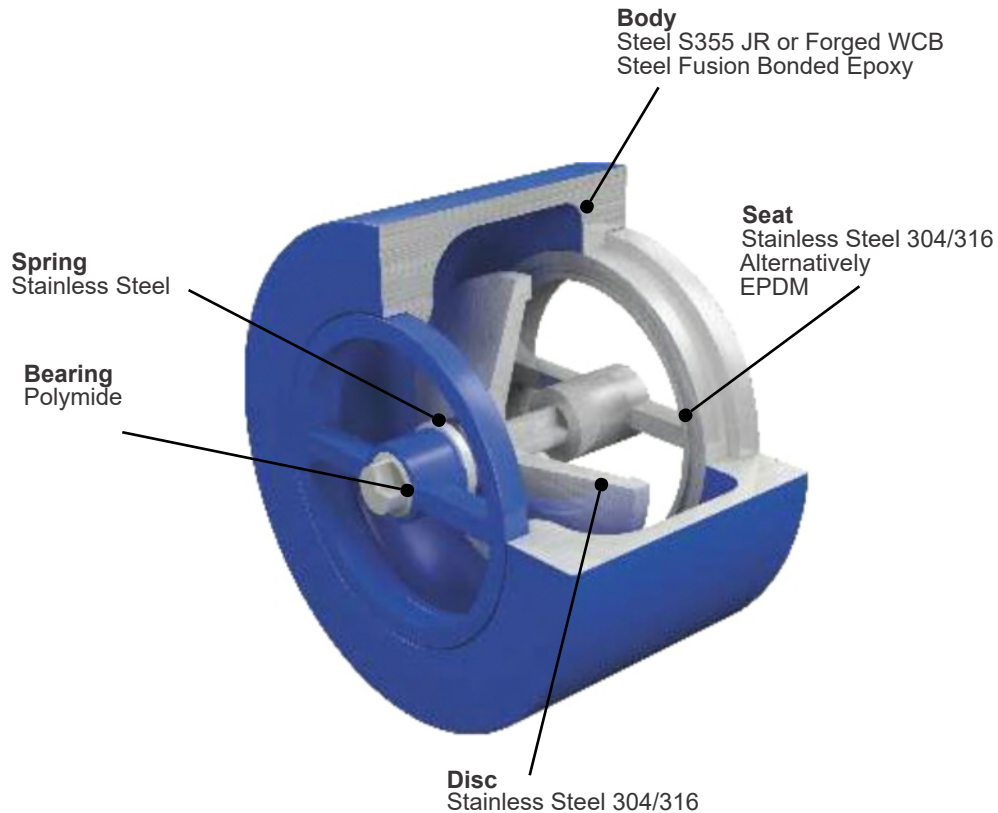

Series AGB Silent Check Valves Wafer Features and Benefits

- **Compact Design** - Short face-to-face dimensions makes for economical design of pump stations.
- **Maintenance Free** – The valve has only one moving part resulting in minimal wear and long service life.
- **Surge protection** – CheckFlo Series AGB is a Co-Axial design has a short stroke and a quick dynamic response which minimises damaging water hammer.
- **Low Headloss** – The valve body and disc specifically designed for low pressure loss across the valve. In addition, the flow areas around the valve seat is 110% larger than the inlet area of the valve. Flow paths through the valve are specifically profiled to ensure full opening of the disc at low flows.
- **Tight shutoff** – This is accomplished by means of metal-to-metal seating or alternatively a soft dynamic seat.
- **Highly customisable** – CheckFlo Series AGB is designed to suit almost any application and can be supplied in a wide variety of materials, end connections, pressure ratings and face-to-face dimension to suit the client's application.
- **Technical support** – We provide assistance with surge analysis and protection strategies as well as spring selection for specific critical velocity and valve response requirements.

CheckFlo Series AGB Silent Check valves are aligned with AirFlo Variable Orifice Air Valves for holistic pipeline surge protection

Series AGB Silent Check Valves Materials of Construction

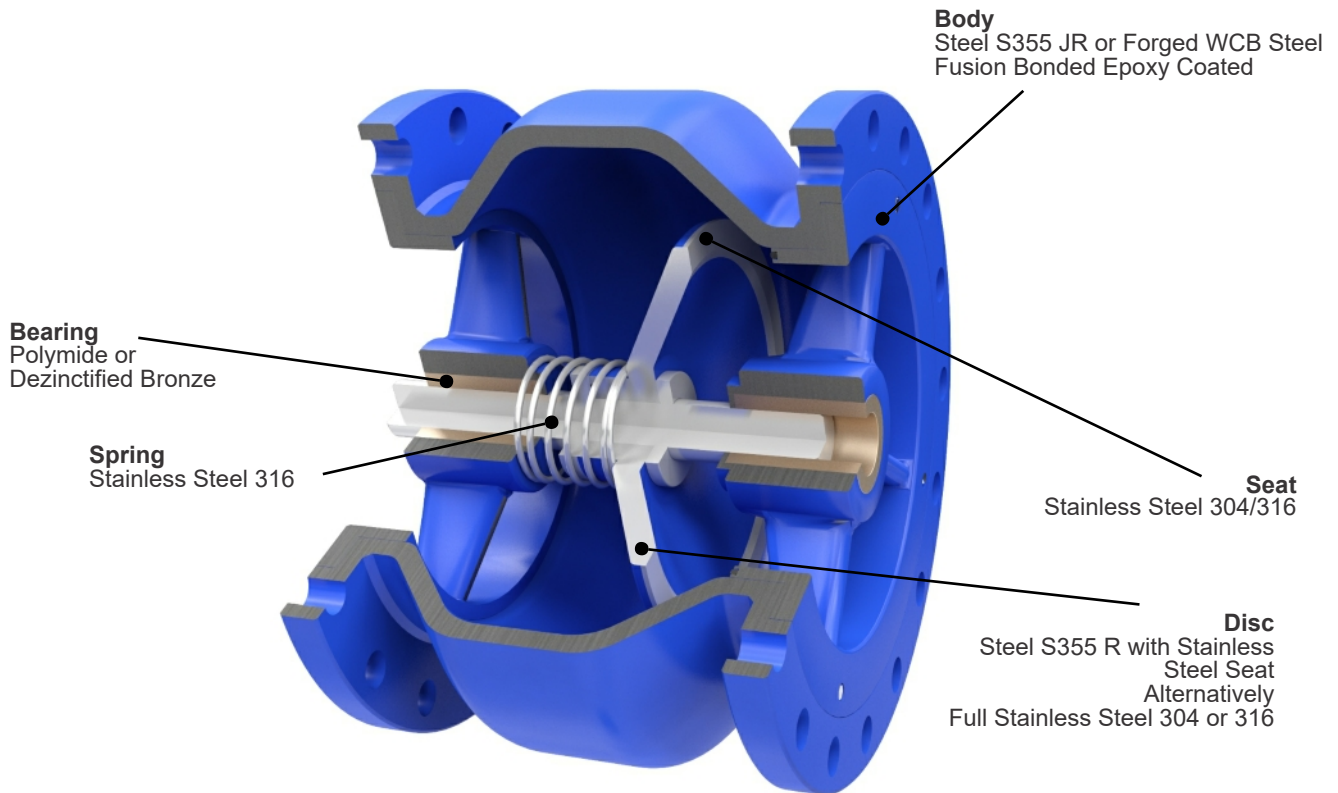

Series AGB Silent Check Valves Features and Benefits

- **Maintenance free** – The valve has only one moving part resulting in minimal wear and long service life.
- **Surge protection** – All CheckFlo designs have a short stroke and a quick dynamic response minimising damaging water hammer.
- **Tight shutoff** – This is accomplished by means of metal-to-metal conical seating for perfect self-alignment or alternatively a soft dynamic seat can be provided on request.
- **Technical support** – We provide assistance with surge analysis and protection strategies as well as spring selection for specific critical velocity and valve response requirements.

CheckFlo Series AGB Silent Check Valves are aligned with AirFlo Variable Orifice air valves to minimise surge and water hammer in pipeline systems.

Series DGB-SF Nozzle Check Valves Weights and Dimensions

<p>DESIGN TYPE CheckFlo Short Face-to-Face Central Shaft Nozzle Check Design</p> <p>ACCEPTABLE MEDIA Water and Strained Raw Water</p> <p>OPERATING PRESSURE RANGE PN 10 to PN63</p> <p>OPERATING TEMPERATURE RANGE -5° TO 80°</p> <p>SIZE RANGE DN50 to DN1200</p> <p>STANDARD FACTORY TESTS Body 1.5 times PN</p>	<p>END CONNECTION: Wafer Design: suitable for alignment to SAN 1123, BS 4504 or EN 1092 or ANSI B16.5 flanges</p> <p>MATERIALS OF CONSTRUCTION</p> <ul style="list-style-type: none"> - Steel Body, Difussor, Disc FBE coated to 300 microns as standard - Stainless Steel Spring, Seat and Trim - Optional - Stainless Steel Disc or Complete Stainless Steel construction <p>FUNCTION</p> <ul style="list-style-type: none"> - Low headloss - provides energy saving - Quick response - prevents surge and waterhammer - Short Face to Face - savings in space and cost - Maintenance free - savings in Life Cycle Costing
----------------------------------------------------------------------------------------------------------------------------------------------------------------------------------------------------------------------------------------------------------------------------------------------------------------------------------------------------------------------------------	----------------------------------------------------------------------------------------------------------------------------------------------------------------------------------------------------------------------------------------------------------------------------------------------------------------------------------------------------------------------------------------------------------------------------------------------------------------------------------------------------------------------------------------------------------------------------------------------------------------------------------------------------------------------------------------------------------------------------------

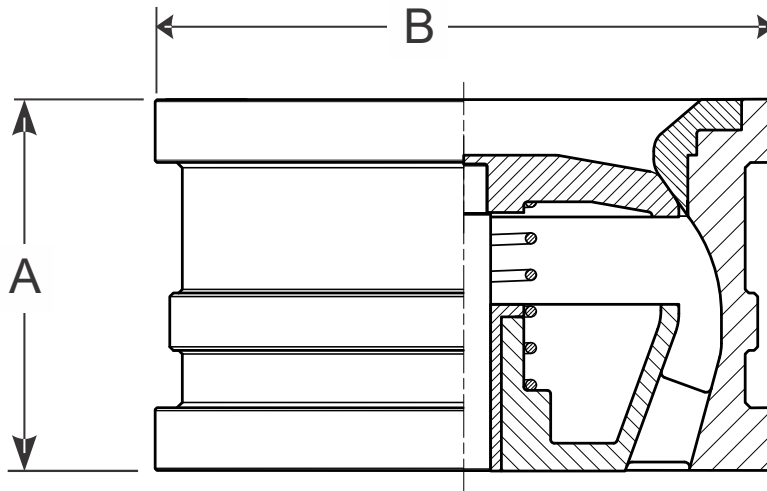

Weights & Dimensions - Wafer Short Face to Face Design

Size DN mm	A mm PN16	B mm PN 16	A mm PN25	B mm PN25	A mm PN 40	B mm PN 40	Weight kg PN16	Weight kg PN25	Weight kg PN40
50	60	100	60	104	60	107	3	3	4
80	73	131	73	145	73	145	6	6	8
100	73	160	73	165	79	188	8	8	11
150	98	216	98	226	137	260	17	17	23
200	127	274	127	301	165	314	31	31	40
250	146	334	146	355	213	395	52	59	89
300	181	403	181	417	239	451	91	101	135
350	184	445	222	478	273	456	102	145	190
400	191	507	232	533	305	558	143	193	230
450	204	542	264	590	362	606	177	281	370
500	219	599	292	647	368	676	247	345	461
600	222	710	318	768	438	783	339	545	790

Series DGB-SF Nozzle Check Valves Weights and Dimensions

<p>DESIGN TYPE CheckFlo Short Face to Face Central Shaft Nozzle Check Design</p> <p>ACCEPTABLE MEDIA Water and Strained Raw Water</p> <p>OPERATING PRESSURE RANGE PN 10 to PN63</p> <p>OPERATING TEMPERATURE RANGE -5° TO 80°</p> <p>SIZE RANGE DN50 to DN1200</p> <p>STANDARD FACTORY TESTS Body 1.5 times PN</p>	<p>END CONNECTION: Flanged: to SAN 1123 , BS 4504 or EN 1092 or ANSI B16.5</p> <p>MATERIALS OF CONSTRUCTION</p> <ul style="list-style-type: none"> - Steel Body, Difussor, Disc FBE coated to 300 microns as standard - Stainless Steel Spring, Seat and Trim - Optional - Stainless Steel Disc or Complete Stainless Steel construction <p>FUNCTION</p> <ul style="list-style-type: none"> - Low headloss - provides energy saving - Quick response - prevents surge and waterhammer - Short Face to Face - savings in space and cost - Maintenance free - savings in Life Cycle Costing
----------------------------------------------------------------------------------------------------------------------------------------------------------------------------------------------------------------------------------------------------------------------------------------------------------------------------------------------------------------------------------	-----------------------------------------------------------------------------------------------------------------------------------------------------------------------------------------------------------------------------------------------------------------------------------------------------------------------------------------------------------------------------------------------------------------------------------------------------------------------------------------------------------------------------------------------------------------------------------------------------------------------------------------------------------------------------------------------

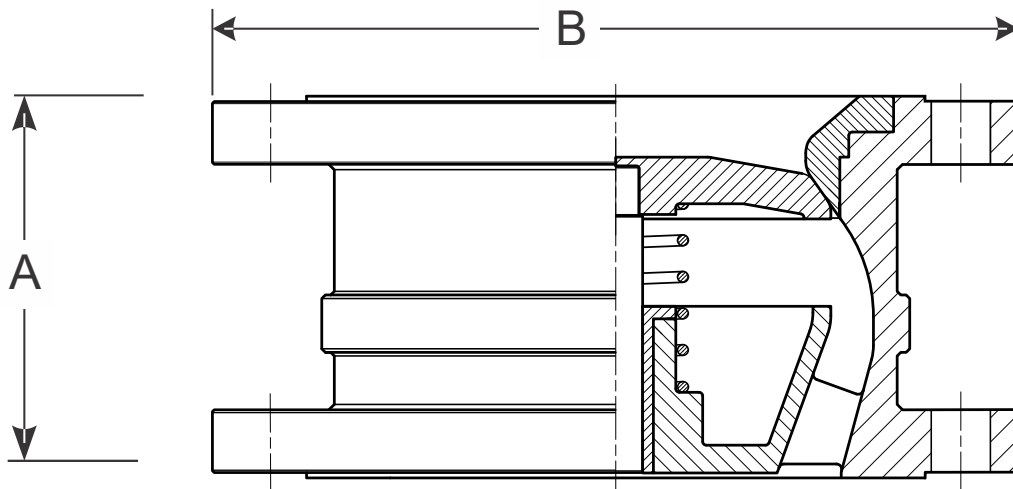

Weights & Dimensions - Flanged Short Face to Face Design

(Valves can also be supplied to EN 558 S14 face to face dimensions or any bespoke length)

Size DN mm	A mm PN16	B mm PN 16	A mm PN25	B mm PN25	A mm PN 40	B mm PN 40	Weight kg PN16	Weight kg PN25	Weight kg PN40
50	60	165	60	165	60	165	6	6	6
80	73	200	73	200	73	200	10	14	16
100	73	220	73	235	79	235	14	20	23
150	98	285	98	300	137	300	38	49	55
200	127	340	127	360	165	375	44	56	74
250	146	405	146	405	213	425	81	95	149
300	181	460	181	485	239	515	123	151	225
350	184	520	222	555	273	580	152	215	300
400	191	580	232	620	305	558	213	243	380
450	204	640	264	670	362	685	267	401	540
500	219	715	292	730	368	755	357	505	703
600	222	840	318	845	438	890	529	775	1180
700	305	910	368	960	505	995	783	1043	1320
800	350	1025	420	1085	570	1140	1020	1260	1720
900	368	1125	483	1185	636	1250	1458	2020	2640
1000	500	1255	568	1320	701	1360	1944	2450	3160
1200	524	1485	629	1530	750	1575	2592	3654	4640

Series DGB-LF Nozzle Check Valves Weights and Dimensions

DESIGN TYPE
CheckFlo Long Face-to-Face Central Shaft Nozzle Check Design

ACCEPTABLE MEDIA
Water and Strained Raw Water

OPERATING PRESSURE RANGE
PN 10 to PN63 - Higher Pressures on request

OPERATING TEMPERATURE RANGE
-5° TO 80°

SIZE RANGE
DN50 to DN1200 - Larger sizes on request

STANDARD FACTORY TESTS
Body 1.5 times PN

END CONNECTIONS
Flanged to SANS 1123, BS 4504 or EN 1092 or ANSI B16.5

MATERIALS OF CONSTRUCTION

- Steel Body, Difussor, Disc FBE coated to 300 microns as standard
- Stainless Steel Spring, Seat and Trim
- Optional - Stainless Steel Disc or Complete Stainless Steel construction

FUNCTION and BENEFITS

- Low headloss - provides energy saving
- Quick response - prevents surge and waterhammer
- Short Face to Face - savings in space and cost
- Maintenance free - savings in Life Cycle Costing

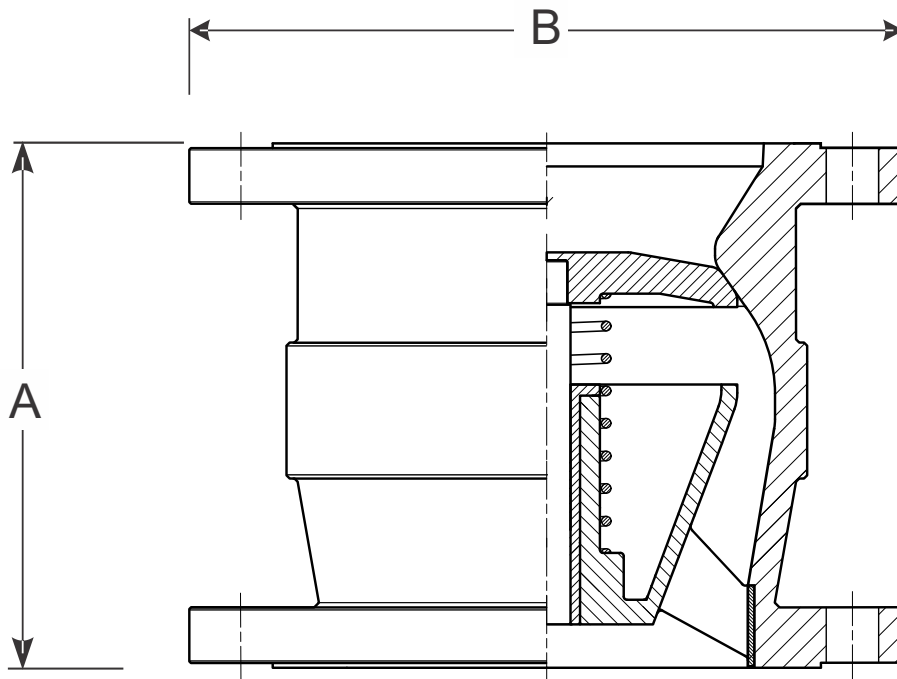

Weights & Dimensions - Flanged Long Face-to-Face Design

Size DN	A mm PN16 to PN40	A mm PN63	B mm PN16	B mm PN25	B mm PN40	B mm PN63	Weight kg PN16	Weight kg PN25	Weight kg PN40	Weight kg PN63
300	350	375	460	485	515	530	180	190	225	302
350	405	440	520	555	580	600	315	280	325	395
400	455	500	580	620	658	670	415	365	430	590
450	520	565	640	670	685	735	480	415	575	770
500	570	625	715	730	755	800	540	545	630	1090
600	685	745	840	845	890	930	900	892	1050	1590
700	800	870	910	960	995	1045	1305	1370	1650	2395
800	910	990	1025	1085	1140	1165	1700	1850	2150	3180
900	1030	1120	1125	1185	1250	1285	2430	2350	3300	4060
1000	1135	1240	1255	1320	1360	1415	3240	3530	3950	5370
1200	1365	1485	1485	1530	1575	1665	4320	5205	5800	8700

Series BCB-SF Nozzle Check Valves Weights and Dimensions

DESIGN TYPE
CheckFlo Short Face-to-Face Annular Disc Nozzle Check Design

ACCEPTABLE MEDIA
Water and Strained Raw Water

OPERATING PRESSURE RANGE
PN 10 to PN63 - Higher Pressures on request

OPERATING TEMPERATURE RANGE
-5° TO 80°

SIZE RANGE
DN300 to DN1200 - Larger sizes on request

STANDARD FACTORY TESTS
Body 1.5 times PN

END CONNECTIONS
Flanged to SANS 1123, BS 4504 or EN 1092 or ANSI B16.5

MATERIALS OF CONSTRUCTION

- Steel Body, Difussor, FBE coated to 300 microns as standard
- Stainless Steel Disc, Spring, Seat and Trim
- Optional - Complete Stainless Steel construction

FUNCTION and BENEFITS

- Low headloss - provides energy saving
- Quick response - prevents surge and waterhammer
- Short Face to Face - savings in space and cost
- Maintenance free - savings in Life Cycle Costing

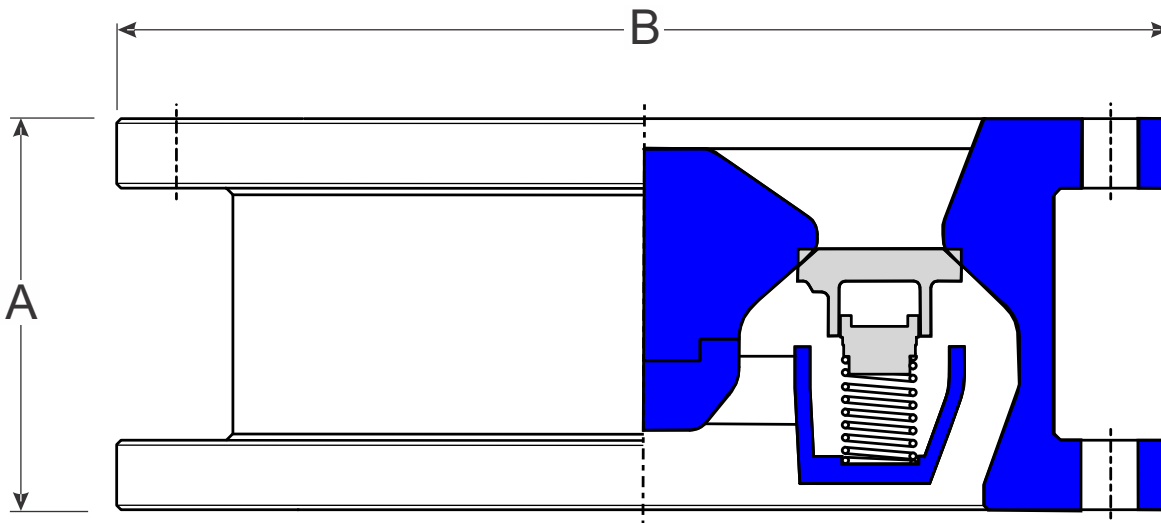

Weights & Dimensions - Flanged Short Face-to-Face Design

Size DN	A mm PN16 to PN40	A mm PN63	B mm PN16	B mm PN25	B mm PN40	B mm PN63	Weight kg PN16	Weight kg PN25	Weight kg PN40	Weight kg PN63
300	181	229	460	485	515	530	101	114	132	172
350	222	273	520	555	580	600	138	156	178	274
400	245	305	580	620	658	670	181	224	272	379
500	305	368	715	730	755	800	358	341	397	599
600	370	394	840	845	890	930	579	546	681	1384
700	430	480	910	960	995	1045	712	805	946	1405
800	500	584	1025	1085	1140	1165	992	930	992	1730
900	560	635	1125	1185	1250	1285	1490	1065	1240	2325
1000	650	720	1255	1320	1360	1415	1910	2061	2215	2590
1200	740	930	1485	1530	1575	1665	2790	3280	3540	4535

Series BCB-LF Nozzle Check Valves Weights and Dimensions

DESIGN TYPE

CheckFlo Long Face-to-Face Annular Disc Nozzle Check Design

ACCEPTABLE MEDIA

Water and Strained Raw Water

OPERATING PRESSURE RANGE

PN 10 to PN63 - Higher Pressures on request

OPERATING TEMPERATURE RANGE

-5° TO 80°

SIZE RANGE

DN300 to DN1200 - Larger sizes on request

STANDARD FACTORY TESTS

Body 1.5 times PN

END CONNECTIONS

Flanged to SANS 1123, BS 4504 or EN 1092 or ANSI B16.5

MATERIALS OF CONSTRUCTION

- Steel Body, Difussor, FBE coated to 300 microns as
- Stainless Steel Disc, Spring, Seat and Trim
- Optional - Complete Stainless Steel construction

FUNCTION and BENEFITS

- Low headloss - provides energy saving
- Quick response - prevents surge and waterhammer
- Short Face to Face - savings in space and cost
- Maintenance free - savings in Life Cycle Costing

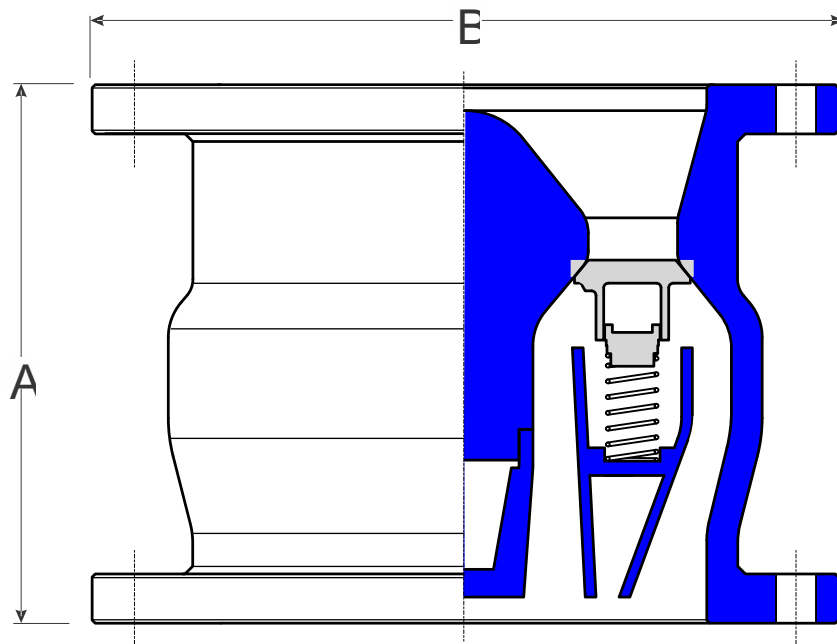

Weights & Dimensions - Flanged Long Face-to-Face Design

Size DN	A mm PN16 to PN40	A mm PN63	B mm PN16	B mm PN25	B mm PN40	B mm PN63	Weight kg PN16	Weight kg PN25	Weight kg PN40	Weight kg PN63
300	350	375	460	485	515	530	175	185	221	294
350	405	440	520	555	580	600	310	270	322	388
400	455	500	580	20	558	670	410	355	420	584
450	520	565	640	670	685	735	470	402	565	765
500	570	625	715	730	755	800	530	535	620	1070
600	685	745	840	845	890	930	890	875	1020	1567
700	800	870	910	960	995	1045	1295	1368	1630	2375
800	910	990	1025	1085	1140	1165	1680	1841	2130	3165
900	1030	1120	1125	1185	1250	1285	2415	2339	3250	4050
1000	1135	1240	1255	1320	1360	1415	3220	3517	3915	5365
1200	1365	1485	1485	1530	1575	1665	4298	5190	5780	8680

Series AGB Wafer Silent Check Valves Weights and Dimensions

<p>DESIGN TYPE CheckFlo Wafer Silent Check Design</p> <p>ACCEPTABLE MEDIA Water and Strained Raw Water</p> <p>OPERATING PRESSURE RANGE PN 10 to PN25 - Higher Pressures on request</p> <p>OPERATING TEMPERATURE RANGE -5° TO 80°</p> <p>SIZE RANGE DN50 to DN300 - Larger sizes on request</p> <p>STANDARD FACTORY TESTS Body 1.5 times PN</p>	<p>END CONNECTIONS Wafer design to suit SANS 1123, BS 4504 or EN 1092 or ANSI B16.5</p> <p>MATERIALS OF CONSTRUCTION - Steel Body and guiding FBE coated to 300 microns as standard - Stainless Steel Disc, Spring, Seat and Trim - Optional - Complete Stainless Steel construction</p> <p>FUNCTION and BENEFITS - Quick response - prevents surge and waterhammer - Maintenance free - savings in Life Cycle Costing</p>
------------------------------------------------------------------------------------------------------------------------------------------------------------------------------------------------------------------------------------------------------------------------------------------------------------------------------------------------------------------------------------------------------------------	-------------------------------------------------------------------------------------------------------------------------------------------------------------------------------------------------------------------------------------------------------------------------------------------------------------------------------------------------------------------------------------------------------------------------------------------------------------------------

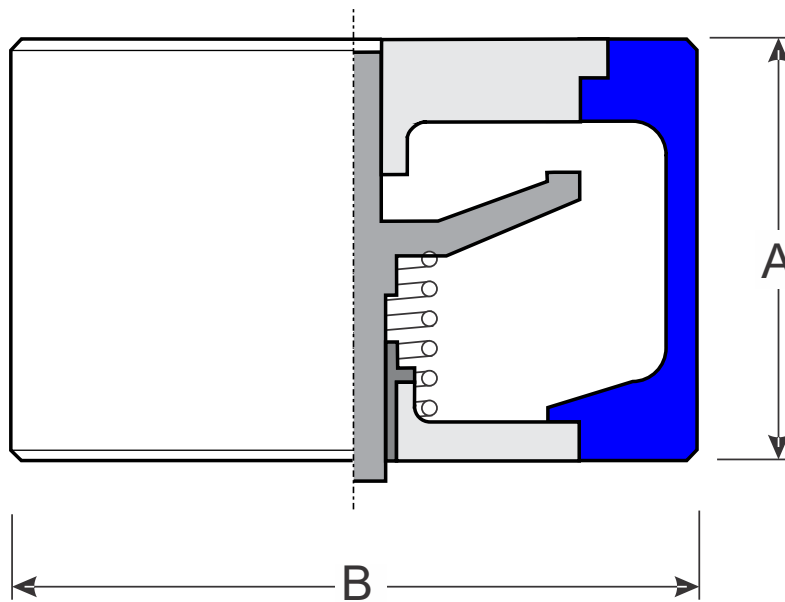

Weights & Dimensions - Wafer Design

Size DN mm	A mm PN16 & PN25	B mm PN16	B mm PN25	Weight kg PN16	Weight kg PN25
50	67	100	104	3	4
80	70	131	145	7	8
100	102	160	165	11	12
150	140	216	226	25	27
200	165	274	301	45	59
250	210	334	355	64	68
300	286	403	417	168	174

Series AGB Silent Check Valves Weights and Dimensions

DESIGN TYPE CheckFlo Flanged Silent Check Design
ACCEPTABLE MEDIA Water and Strained Raw Water
OPERATING PRESSURE RANGE PN 10 to PN40
OPERATING TEMPERATURE RANGE -5° TO 80°
SIZE RANGE DN80 to DN1200
STANDARD FACTORY TESTS Body 1.5 times PN

END CONNECTIONS Wafer design to suit SANS 1123, BS 4504 or EN 1092 or ANSI B16.5
MATERIALS OF CONSTRUCTION - Steel Body, Disc and Guiding - FBE coated to 300 microns as standard - Stainless Steel Spring, Seat and Trim - Polymide or Dezincified Bronze bearings - Optional - Complete Stainless Steel construction
FUNCTION and BENEFITS - Quick response - prevents surge and waterhammer - Maintenance free - savings in Life Cycle Costing

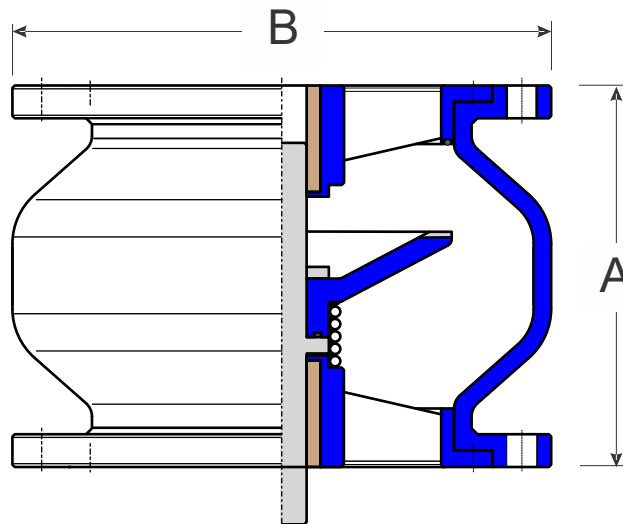

Weights & Dimensions - Flanged Design

Size DN	A mm PN16 to PN40	B mm PN16	B mm PN25	B mm PN40	Weight kg PN16	Weight kg PN25	Weight kg PN40
80	150	200	200	200	12	12	12
100	185	220	235	235	15	17	17
150	230	285	285	300	28	28	32
200	250	340	360	375	46	52	60
250	305	405	425	450	87	98	114
300	365	460	485	515	101	114	132
350	400	520	555	580	138	156	178
400	450	580	20	558	181	224	272
450	475	640	670	685	304	290	337
500	525	715	730	755	463	437	545
600	610	840	845	890	570	644	757
700	670	910	960	995	744	698	744
800	705	1025	1085	1140	894	639	744
900	790	1125	1185	1250	1127	1216	1307
1000	880	1255	1320	1360	1646	1935	2089

Nozzle Check Performance Characteristics

Valve Opening Pressure

On initial system start-up, the upstream pressure applied by the flow to the front of the disc is required to overcome the force of the spring and any upstream back pressure acting on the back of the disc. The pressure differential at which this happens is known as the "cracking pressure". When the pressure differential exceeds the cracking pressure, the valve disc is moved from the valve seat and thereby initiating media flow through the valve.

As soon as flow is initiated, the pressure differential is overcome and the disc is kept open by the fluid velocity.

Critical Velocity

All check valves should be used in the fully open position. The flow velocity required to keep the valve fully open is known as the Critical Velocity.

CheckFlo offers as standard four spring options to ensure a fully opened valve at four different critical velocities. However, we can customise the spring to satisfy the client's specific needs.

The CheckFlo valve can be installed in any position. For valves that are installed in a vertical flow or inclined flow position where the disc is facing down, it must be noted that the fluid velocity must be sufficient to overcome the weight vector of the disc in addition to the Critical Velocity of the spring.

Please consult CheckFlo for flow velocities different to those highlighted below:

Standard Spring Options	Critical Velocity
Spring N1	1.5 m/s
Spring N2	2.0 m/s
Spring N3	2.5 m/s
Spring N4	3.0 m/s

Valve Chatter

Chatter or flutter is a common occurrence in Conventional Swing Check and Double Door Check Valves. The CheckFlo Nozzle Check valve has been designed to ensure that it takes full advantage of the Venturi effect created by the flow and the valve body contours to keep the disc positively open at the critical flow conditions.

Surge and Waterhammer

The CheckFlo valve has been designed to close in that critical low millisecond at the point where flow reversal is about to occur. Closing reaction time is 0.3 seconds.

The quick closure and short and linear travel of the valve's disc substantially minimises surge in pipelines.

Nozzle Check Performance Characteristics

Long Face-to-Face All Sizes and Pressure Ratings

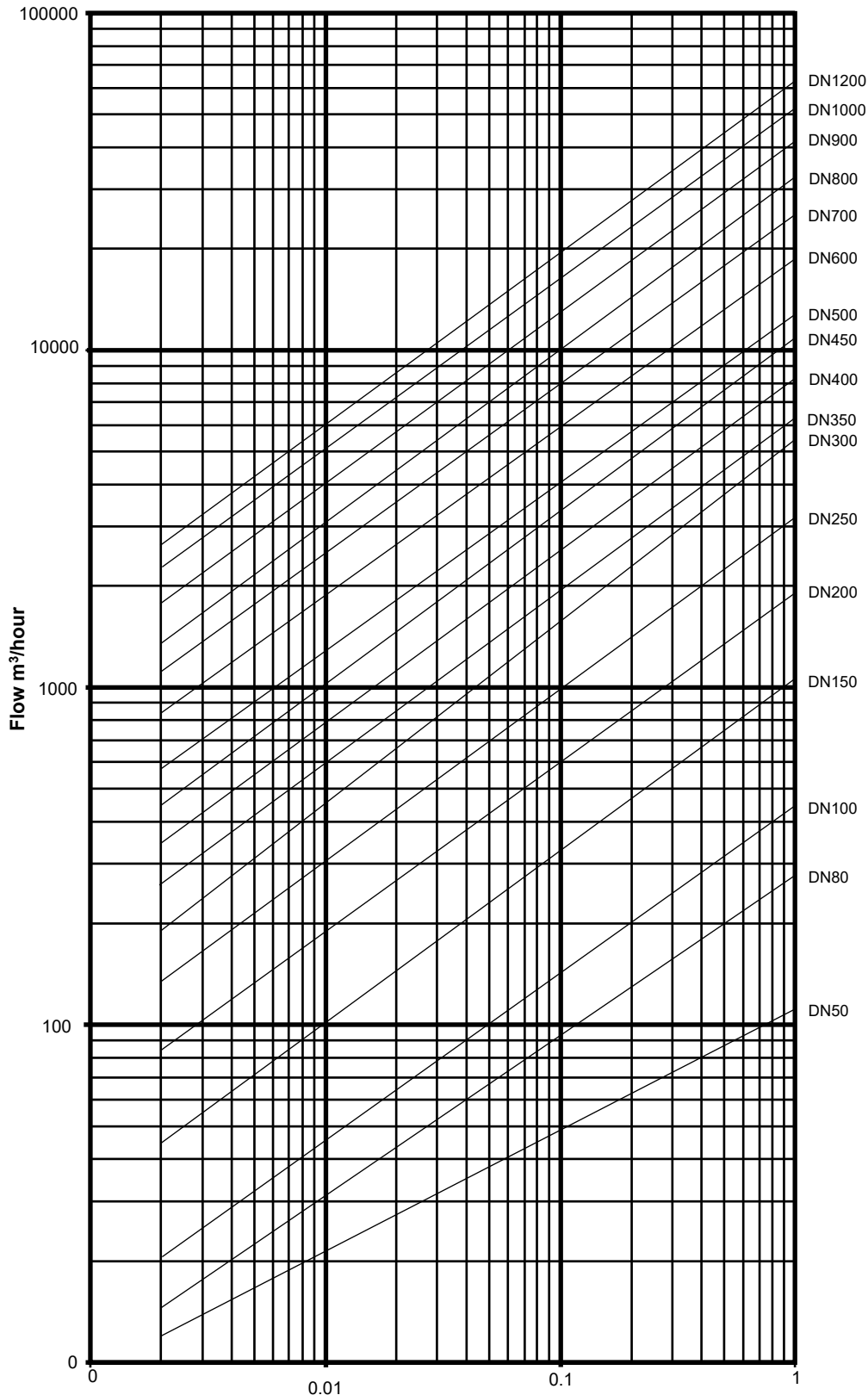

DN mm	Kv
50	120
80	282
100	452
150	1071
200	1966
250	3163
300	4425
350	6127
400	8146
450	10436
500	13046
600	19029
700	26601
800	32353
900	41063
1000	50851
1200	61129

$$Q = Kv \cdot \sqrt{\frac{\Delta P}{SG}}$$

Q: Flow rate m³/hour
 ΔP: Pressure Drop bar
 SG: Specific Gravity (1 for water)
 Kv: Flow coefficient

Nozzle Check Valve Performance Characteristics

Short Face-to-Face all Sizes and Pressure Ratings

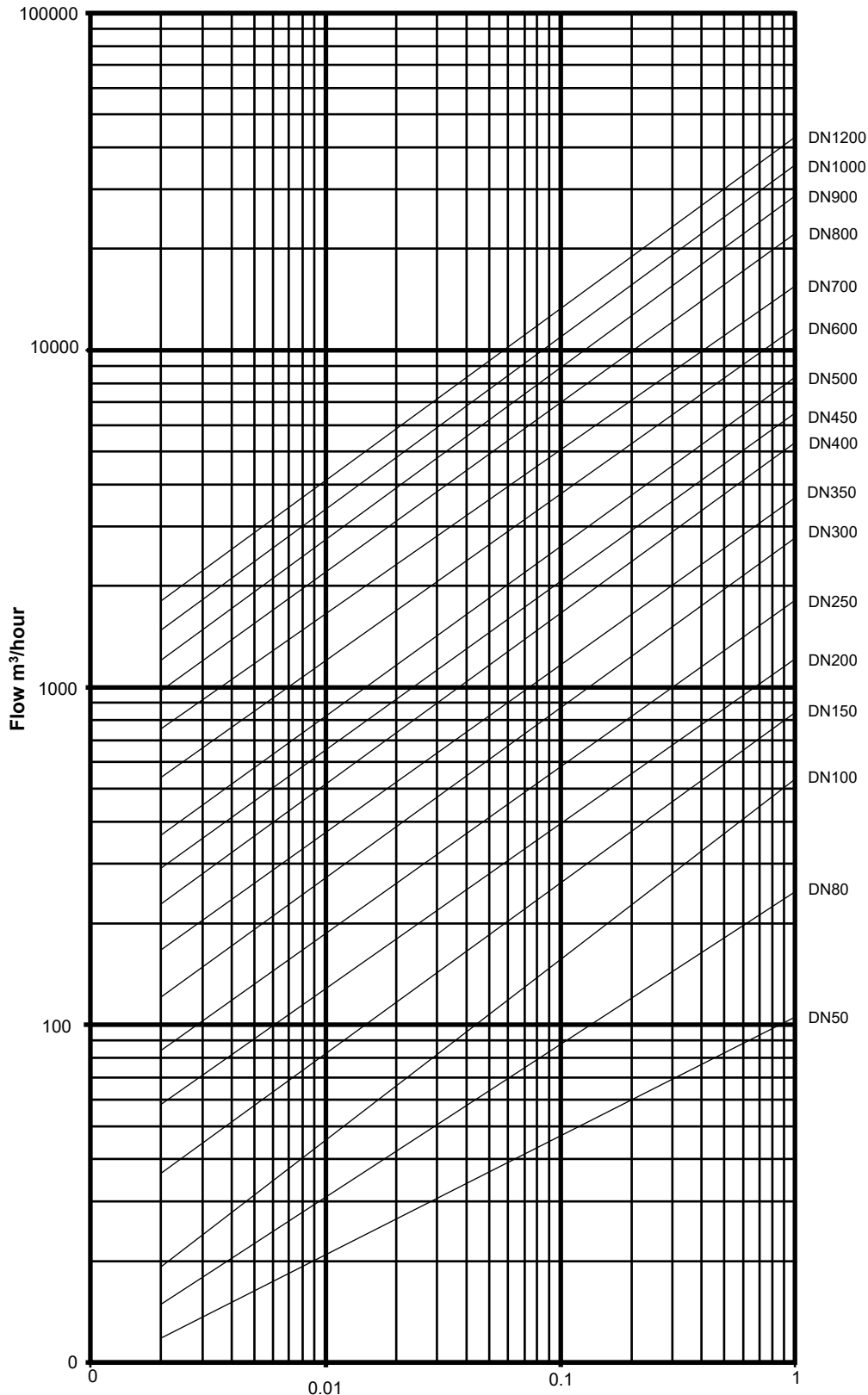

DN mm	Kv
50	103
80	259
100	430
150	825
200	1310
250	1875
300	2808
350	3884
400	5158
450	6609
500	8262
600	12051
700	16893
800	22168
900	28136
1000	34844
1200	41887

$$Q = Kv \cdot \sqrt{\frac{\Delta P}{SG}}$$

Q: Flow rate m³/hour
 ΔP: Pressure Drop bar
 SG: Specific Gravity (1 for water)
 Kv: Flow coefficient

Silent Check Valve Performance Characteristics

All Sizes and Pressure Ratings

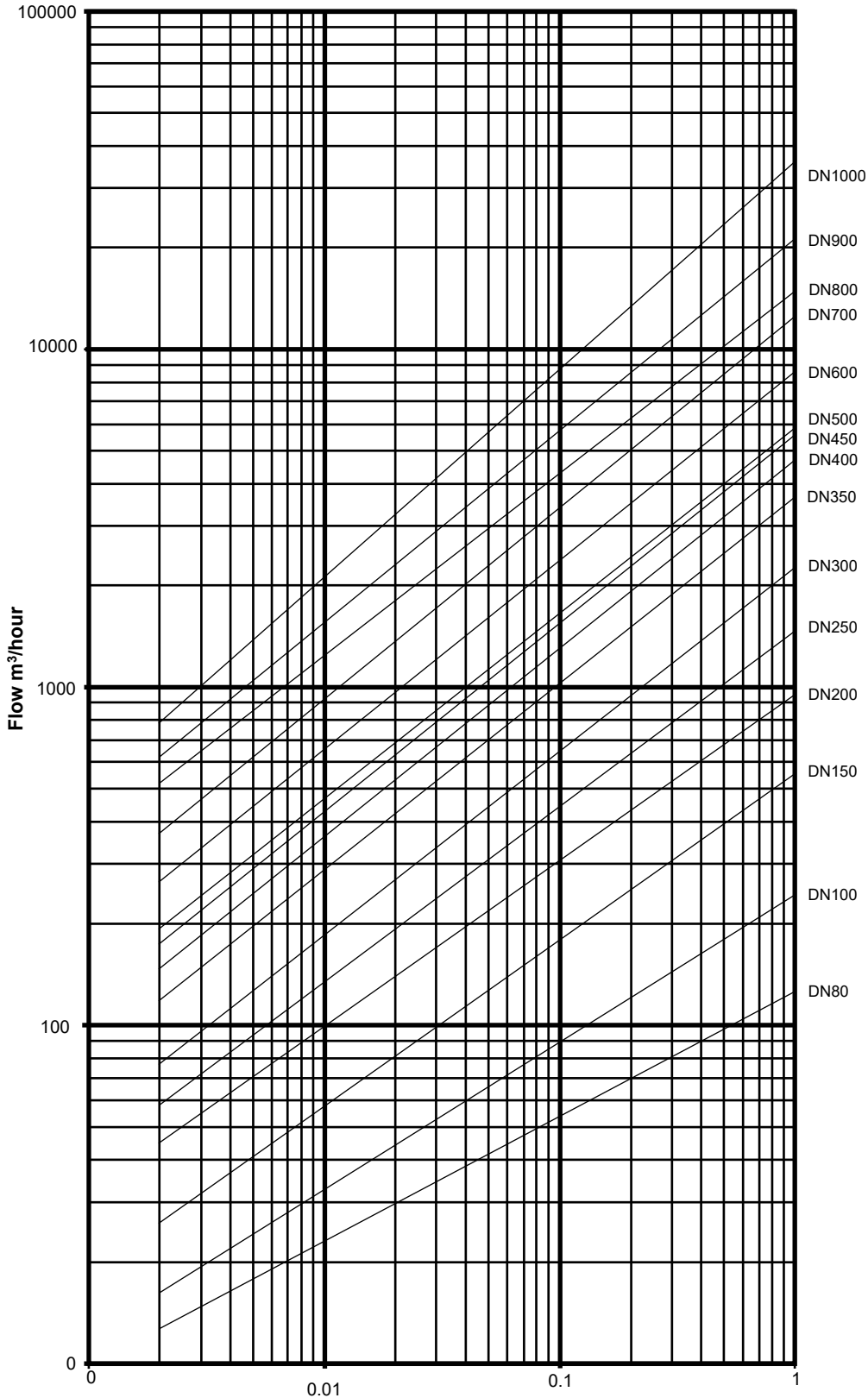

DN mm	Kv
80	135
100	430
150	540
200	965
250	1531
300	2163
350	3806
400	4844
450	5717
500	6969
600	8650
700	12126
800	15909
900	20196
1000	25011

$$Q = Kv \cdot \sqrt{\frac{\Delta P}{SG}}$$

Q: Flow rate m³/hour
 ΔP: Pressure Drop bar
 SG: Specific Gravity (1 for water)
 Kv: Flow coefficient

Considerations when Selecting a Check Valve

Introduction

To design a successful pipeline system requires the consideration of the pipeline profile and the combined characteristics of the pump, check valve, air valve, control valve, pipeline material and surge equipment.

Each pipeline component should be analysed in an optimising process that considers not only the initial capital cost but the sum of all costs during the total lifetime of the system, with the aim of preserving limited valuable resources, such as energy, water and capital.

With regards to Check Valve Selection specifically the following should be considered:

Effects on Surge and Water Hammer (Non-Slam Characteristics)

Check Valves of different designs either prevent or create Waterhammer. When a pump trips or is shut down, the forward momentum of the flow decreases. When the forward flow stops, a reverse flow will be initiated. Depending on the system conditions, the reversal of flow can happen quickly (in 0.15 seconds or less). The speed at which a check valve closes affect the valve's potential for preventing pressure transients (water hammer). The faster the closure the lower the surge transient.

CheckFlo's Nozzle Check and Silent Check Valve are both co-axial designs with a very short and linear stroke. Both designs' closure is spring assisted and therefore close in the low milli second timespan before column separation occurs thereby preventing flow reversal and minimising potential surge pressures.

Energy Costs over the entire Life Cycle of the System (head loss characteristics)

All check valves create head loss; and head loss costs money through increase in energy consumption by pumps. The importance of head-loss cannot be over emphasised in a pumping main considering, that 70% of a pump's running costs is power related. It is important therefore to choose a check with a low head loss characteristic.

There are three design factors that will affect the amount of head loss created by a check valve namely; total flow area, the valve's body configuration and, how the operating disc interacts with the flow.

CheckFlo's Nozzle Check Valve provides a very low head loss by utilising the Venturi principle to recover pressure across the valve. In addition, the valve has a diffuser which when combined with the body's flow path creates a low pressure zone behind the disc to overcome the force of the spring thereby providing and even lower head loss across the valve.

CheckFlo Silent Check Valves provides a higher head loss than our Nozzle Check Valve design because of the absence of the diffuser. However the head loss across the valve is relatively low in comparison to other designs as the flow path through the valve is 110% of the initial inlet area.

CheckFlo Swing Check Valves are specifically designed so that the disc in the fully open position forms a hydrofoil which ensures low head loss across the valve.

Long Term Service

The entire range of CheckFlo check valves are designed to be virtually maintenance free. Each design has only one moving part. In addition, each valve's flow path and disc design is such that it prevents flutter and wear during full flow thereby further reducing the need for maintenance. All CheckFlo designs are either supplied in a soft seat or metal-to-metal seated design to suit the most severe applications.



Considerations when Selecting a Check Valve

Initial Cost

All CheckFlo Check Valves are 100% locally manufactured. They are designed to balance initial cost with long term performance. CheckFlo Check valves provide a short face-to-face and a wafer design across its range to ensure cost effective design and building of pump stations. Further, all CheckFlo valves have short lead times.

Conclusion

The CheckFlo range of Check Valves provide the most comprehensive and cost effective response to water hammer protection. Our Check Valves are complemented by the AirFlo Variable range of Air Valves. These two product ranges work in harmony to provide holistic surge and water hammer protection on any pipeline application. All our products are backed up by excellent technical and aftersales support – try us!

Model Numbers

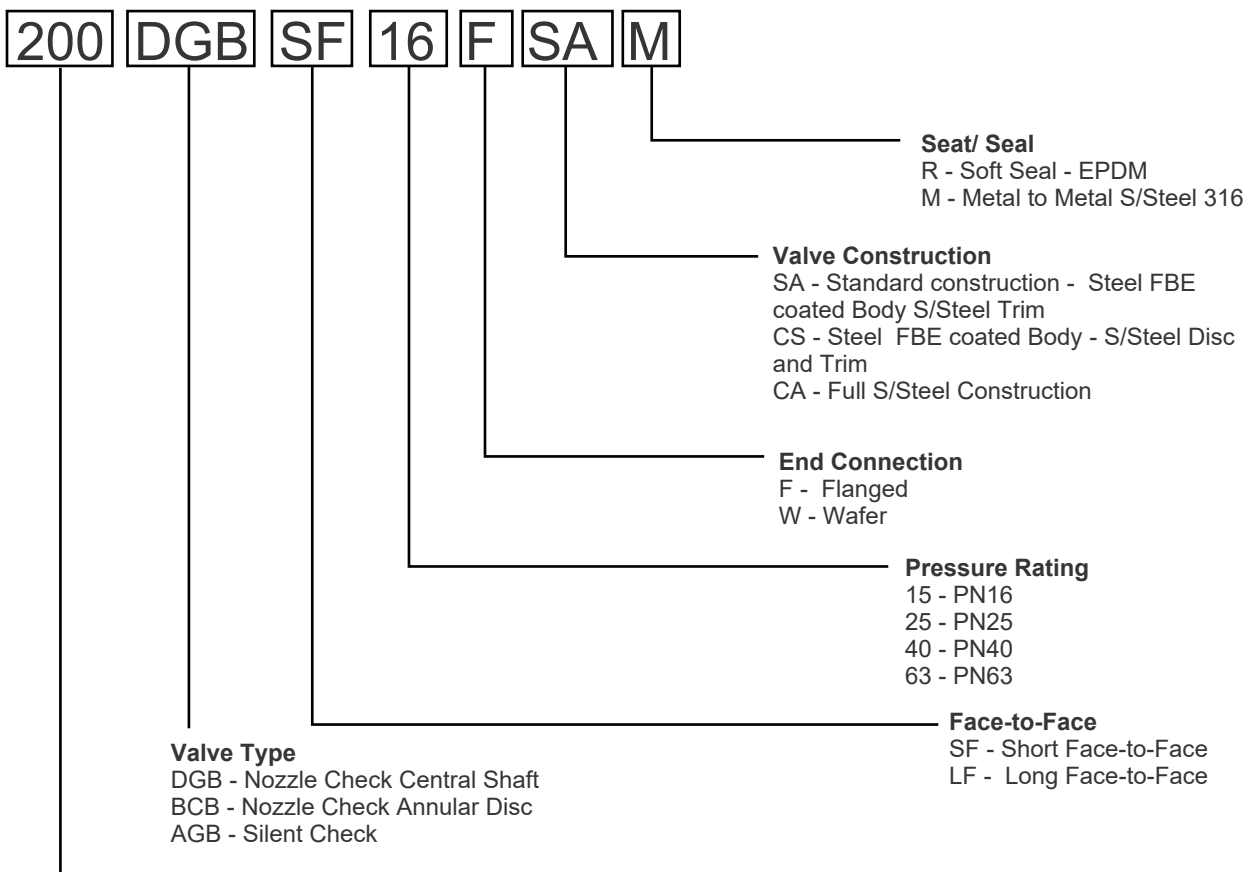

Valve Size:

- 50 - DN50
- 80 - DN80
- 100 - DN100
- 150 - DN150
- 200 - DN200
- 250 - DN250
- 300 - DN300
- 400 - DN400
- 450 - DN450
- 500 - DN500
- 600 - DN600
- 700 - DN700
- 800 - DN800
- 900 - DN900
- 1000 - DN1000
- 1200 - DN1200



Series ESP Model CA Variable Orifice Air Valve is a triple function valve with automatic surge protection for use in potable and strained raw water applications.

Valves are manufactured in full Stainless Steel 304 or 316 as standard. Valves can also be manufactured in Duplex or Super Duplex on request.

Valves are available in sizes DN25 to DN300 and for pressure ratings PN10 to PN100



Series ESP Model SA Variable Orifice Air Valve is a triple function valve with automatic surge protection for use in potable and strained raw water applications

Valves are manufactured in fusion bonded epoxy coated Steel. The top cover, jointing and internal trim are in Stainless Steel 304 or 316.

Valves are available in sizes DN25 to DN300 and for pressure ratings PN10 to PN100



Series ERP Variable Orifice Air Valves is a compact, triple function valve design with automatic surge protection for Sewer and Slurry applications.

Valves are manufactured in Stainless Steel 304 or 316 as standard or epoxy coated Steel with Stainless Steel 304 or 316 trim. Flush ports are optional extras.

Valves are available in sizes DN50 to DN300 and for pressure ratings PN16 and PN25



KII Couplings, Flange Adaptors and Dismantling Joints are of a robust design available in both a wide range and dedicated fit.

All Couplings are available in Fusion Bonded Epoxy Coated Steel or in all Stainless Steel 304 or 316 .

Couplings are available in sizes 40mm to 1600mm and for pressure ratings PN10 to PN40

REXUS Pty Ltd Tel: +27 11 392 4815 E mail: info@rexus.co.za Web: www.rexus.co.za

Nozzle Check and Silent Check Valves for Optimum Surge Protection